

■ ZLJ-400G

Series

■ Contactor Data

Model	ZLJ-400G/□	ZLJ-400G/B□
Contact Form	1H (SPST-NO)	
Contact Material	Ag Alloy	
Contact Rating(at Resistive Load)	400A×48VDC (DC-1)	400A×72VDC (DC-1)
Contact Voltage Drop	≤80mV@400A	
Insulation Resistance	Min. 100MΩ at 500VDC	
Dielectric Strength (Between Insulated Electric Parts)	1000VAC 50 HZ/60 HZ (1 minute) Leak current<1mA	
Pick up time	Max. 40mSec.	
Drop out time	Max. 40mSec.	
Mechanical Operations	100,000 Operations (no load)	
Electrical Operations	6,000 Operations (at rated load)	
Working Duty	Continuous	

■ Coil Data

Model	Coil voltage(V)	Coil Working voltage (V)	Pick-up Voltage (V)	Drop-out Voltage (V)	Starting Current(A)	Holding Current(A)
ZLJ-400G	12	0.85Us~1.1Us	≤70%	≥10%	≤9	≤0.7
	24				≤6	≤0.35
	48				≤3	≤0.2
	60				≤3	≤0.15

■ Part Numbering System

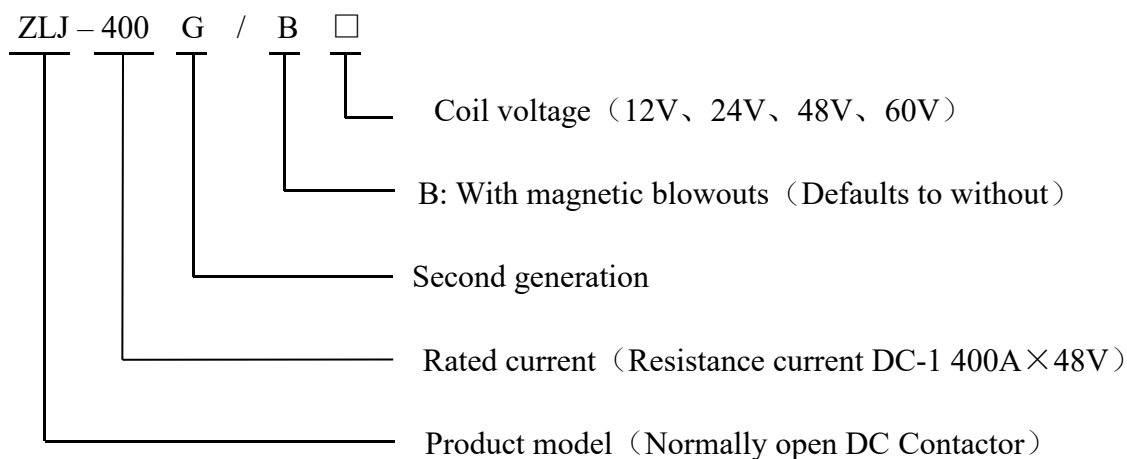

Example: ZLJ-400G/48; means: Normally open DC Contactor, 400A for DC-1 load rated current, coil voltage 48V DC.

■ Shape installation and circuit diagram

ZLJ-400G Unit (mm)

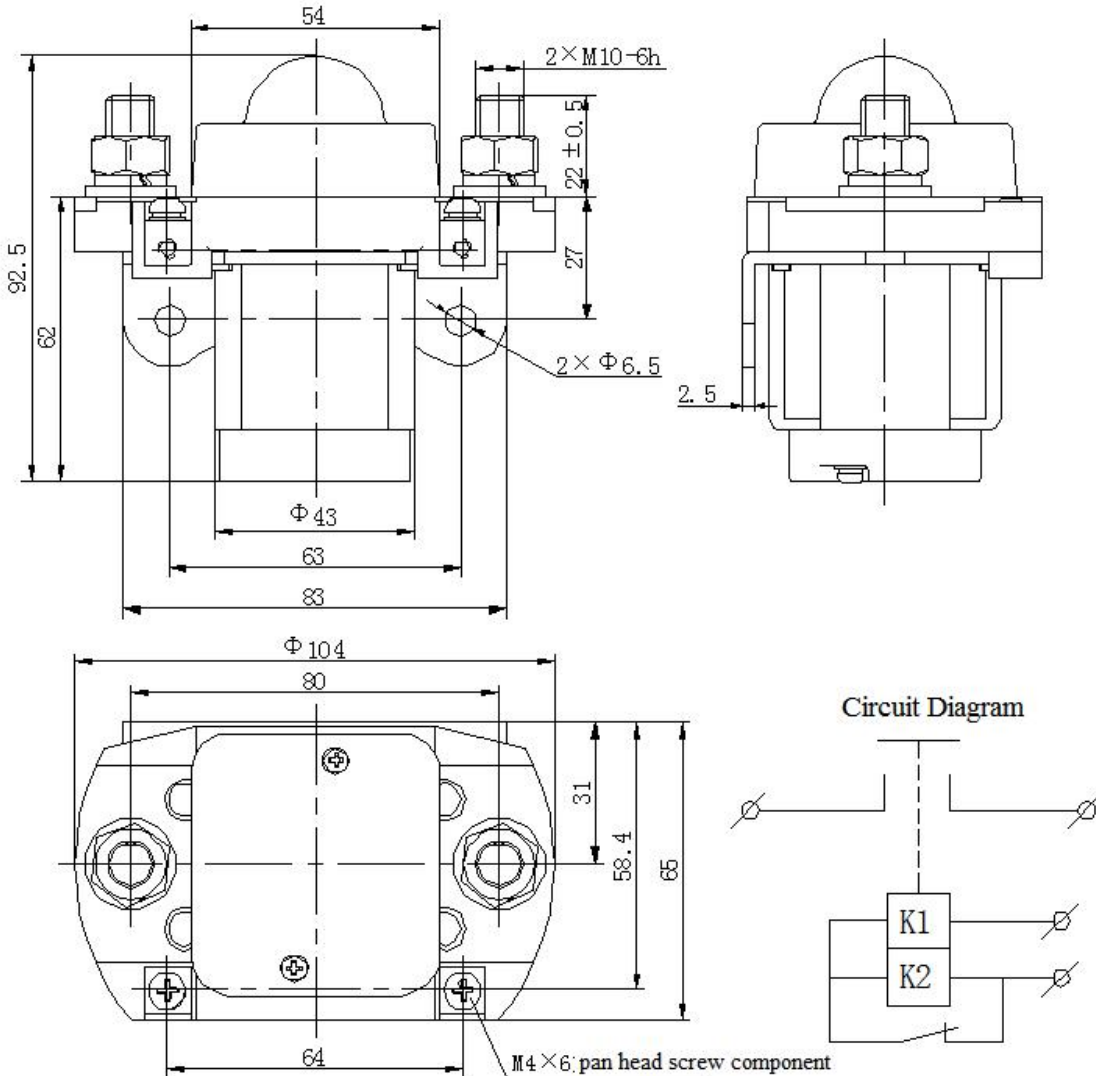

尺寸 (mm) Dimension (mm)	未注尺寸公差 (mm) Tolerance grade not noted (mm)
0~30	± 0.3
31~60	± 0.5
61~100	± 1
>100	± 2

■ Remarks

1. While assemble contactor, tighten torque of nut of terminal screw in main circuit is 10~13N.m; tighten torque of nut of terminal screw in control circuit is 1~1.5N.m.
2. Driving circuit power for coil must be no less than coil power; otherwise, it will reduce cutting capacity of product.
3. Continuous applied voltage should not exceed the maximum permission voltage. Otherwise, abnormal

heating of coil will shorten the life of insulating coating.

4. This contactor is non-waterproof, please don't use in water, solvent, oil and other environment that may contact with the shell or terminal. Otherwise, it may cause abnormal heating due to the burn-in of shell or corrosion, dirty of terminal.